

ULTRA-DEX® 944 & 945 MODULAR & PSC TOOLING SYSTEMS

The ULTRA-DEX® 945 Modular Boring System offers limitless configurations, featuring steel, carbide, and heavy metal bars that can be combined with 28 modular heads.

The enhanced ULTRA-DEX® 944 Series provides a wide range of modular heads and a PSC Connection type tool holder, ensuring seamless compatibility with diverse insert types, shapes, and sizes.



Expanded standard catalog offering

The new quick-change Ultra-Dex® 944 PSC Connection Tool Holding platform complements our existing ULTRA-DEX® 945 Modular Boring System that includes a broad selection of modular heads, offering seamless compatibility with various insert types, shapes, and sizes. Its new Polygon Shank (Capto-compatible*) Connection reduces setup and changeover time in rotating and non-rotating applications.

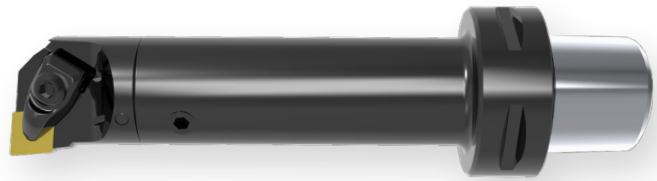
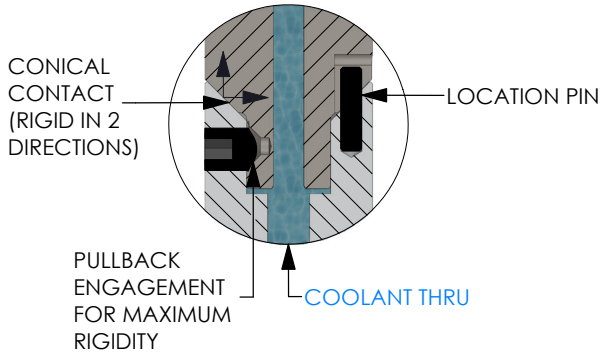

Standard Offering

Available in:

ADINT SD

PSC40, PSC50, PSC63

DCONWS

MH12, MH16, MH20, MH24, MH32

*Capto is a registered trademark of Sandvik Intellectual Property AB of Sweden, and ARCH Cutting Tools is not affiliated, associated, authorized, endorsed by, or in any way officially connected with Sandvik Intellectual Property AB of Sweden.

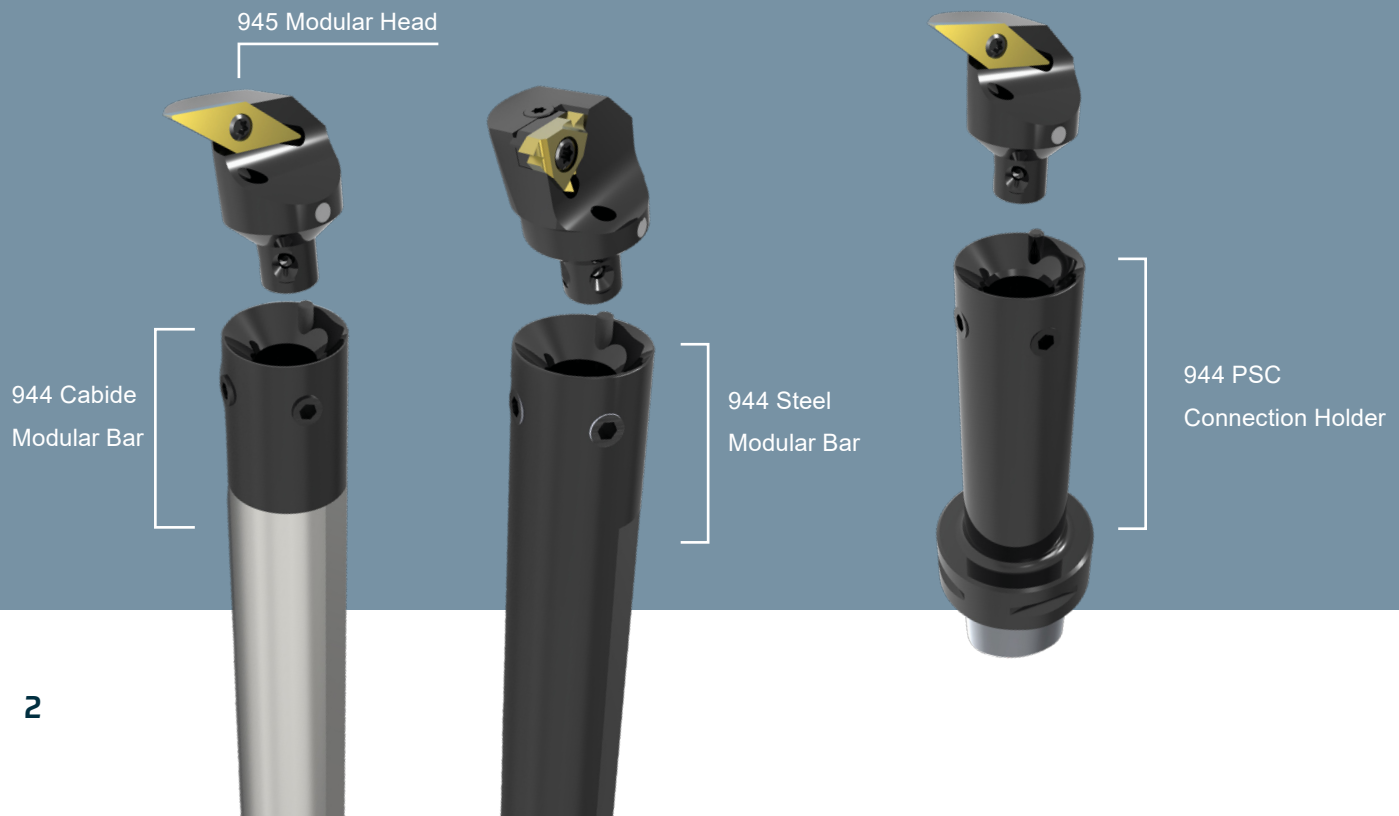

Endless custom PSC Connection type tooling

Enhance machine connectivity and elevate process security with our custom PSC Integral Shank Tooling. Designed to excel in milling, turning, and multi-task machining across all industries, our Capto-compatible* platform ensures optimal performance.

Featuring indexable cutting edges, these optimized tools can be tailored to any insert geometry or material, ensuring versatility, precision, reduced cycle times, and extended tool life. Submit a quote to create a custom Capto-compatible* system engineered for your unique application.

Custom Offering

Available in:

C3, C4, C5, C6, C8, C10

LEARN MORE

Scan the QR code below to build an American-manufactured Custom PSC Integral Shank Tooling System (Capto-compatible*) for your unique application.

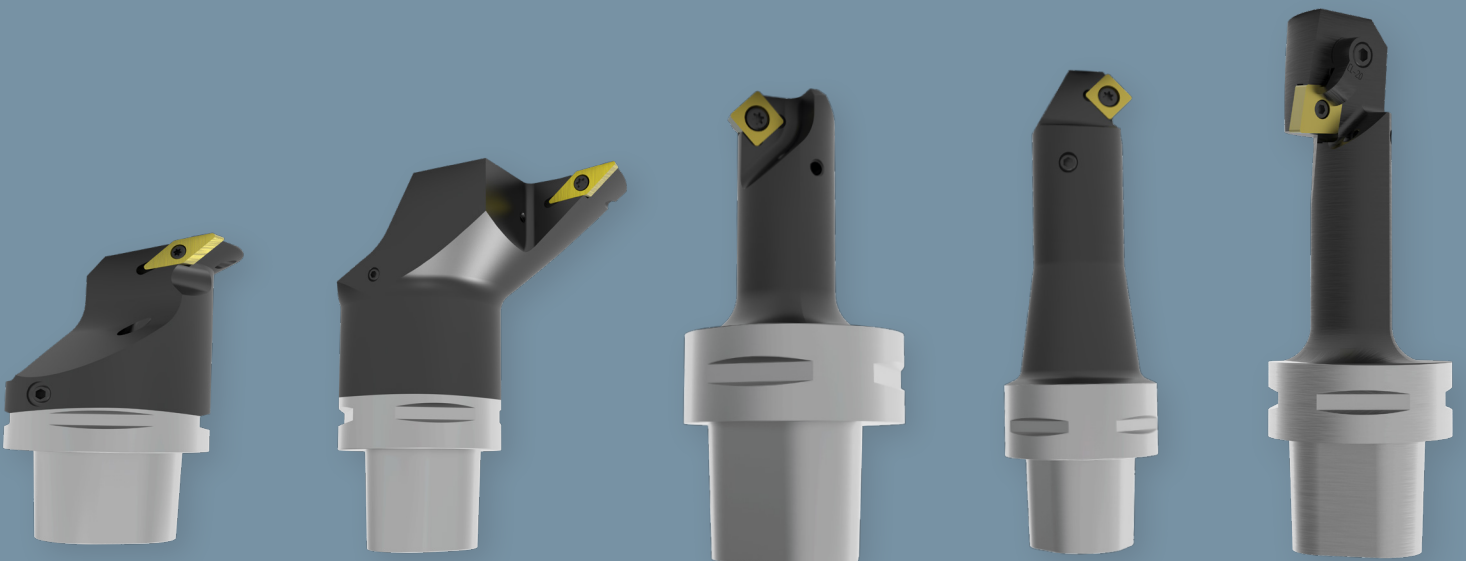

STEEL SHANK

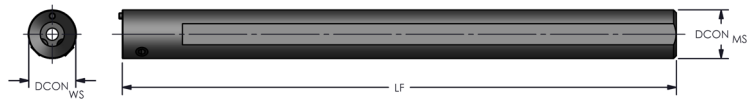

4:1 Ratio					
Product #	Designation	DCONMS [in.]	LF [in.]	DCONWS [in.]	SET SCREW
944-000-019	MBS 1295	0.750	9.500	0.750	MH12S
944-000-020	MBS 1612	1.000	11.500	1.000	MH16S
944-000-021	MBS 2014	1.250	14.000	1.250	MH20S
944-000-022	MBS 2414	1.500	14.000	1.500	MH24S
944-000-023	MBS 2816	1.750	16.000	1.750	MH28S
944-000-024	MBS 3210	2.000	10.000	2.000	MH32S
944-000-025	MBS 3220	2.000	20.000	2.000	MH32S
944-000-026	MBS 4012*	2.500	12.000	2.000	MH32S
944-000-027	MBS 4024*	2.500	24.000	2.000	MH32S
944-000-028	MBS 4828*	3.000	28.000	2.000	MH32S

**2.5" and 3" bars take 2" Head*

CARBIDE SHANK

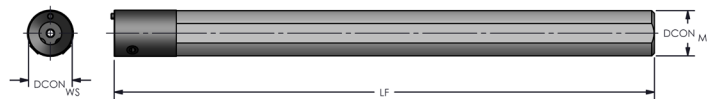

8:1 Ratio					
Product #	Designation	DCONMS [in.]	LF [in.]	DCONWS [in.]	SET SCREW
944-000-002	MB 1295	0.750	9.500	0.750	MH12S
944-000-001	MB 1220M	20.00(mm)	241.00(mm)	19.05(mm)	MH12S
944-000-003	MB 1612	1.000	11.500	1.000	MH16S
944-000-004	MB 2014	1.250	14.000	1.250	MH20S
944-000-005	MB 2414	1.500	14.000	1.500	MH24S
944-000-006	MB 2816	1.750	16.000	1.750	MH28S
944-000-007	MB 3220	2.000	20.000	2.000	MH32S

Product #	Set Screws
968-000-076	MH12S
968-000-077	MH16S
968-000-078	MH20S
968-000-079	MH24S
968-000-080	MH28S
968-000-081	MH32S

HEAVY METAL SHANK



6:1 Ratio					
Product #	Designation	DCONMS [in.]	LF [in.]	DCONWS [in.]	SET SCREW
944-000-008	MBH 1212	0.750	12.000	0.750	MH12S
944-000-009	MBH 1612	1.000	12.000	1.000	MH16S
944-000-010	MBH 2012	1.250	12.000	1.250	MH20S
944-000-011	MBH 2412	1.500	12.000	1.500	MH24S
944-000-012	MBH 2414	1.500	14.000	1.500	MH24S
944-000-013	MBH 2812	1.750	12.000	1.750	MH28S
944-000-014	MBH 2816 *	1.750	16.000	1.750	MH28S
944-000-015	MBH 3212	2.000	12.000	2.000	MH32S
944-000-016	MBH 3218 *	2.000	18.000	2.000	MH32S
944-000-017	MBH 4024 **	2.500	24.000	2.000	MH32S
944-000-018	MBH 4828 **	3.000	28.000	2.000	MH32S

*non-stock item; call for delivery **2.5" and 3" bars take 2" Head

PRODUCT EXPANSION - PSC CONNECTION TOOL HOLDER

STEEL SHANK

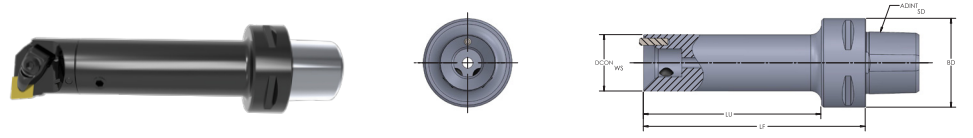

PRODUCT #	DESIGNATION	ADINT SD	DCONWS	BD [mm]	LF [mm]	LU [mm]	SCREW
944-001-100	PSC40-MBS12	PSC40	MH12	40.00	75.00	55.00	MH12S
944-001-101	PSC40-MBS16	PSC40	MH16	40.00	100.00	80.00	MH16S
944-001-102	PSC40-MBS20	PSC40	MH20	40.00	115.00	95.00	MH20S
944-001-103	PSC50-MBS12	PSC50	MH12	50.00	75.00	55.00	MH12S
944-001-104	PSC50-MBS16	PSC50	MH16	50.00	100.00	80.00	MH16S
944-001-105	PSC50-MBS20	PSC50	MH20	50.00	115.00	95.00	MH20S
944-001-106	PSC50-MBS24	PSC50	MH24	50.00	135.00	115.00	MH24S
944-001-107	PSC63-MBS20	PSC63	MH20	63.00	120.00	98.00	MH20S
944-001-108	PSC63-MBS24	PSC63	MH24	63.00	140.00	118.00	MH24S
944-001-109	PSC63-MBS32	PSC63	MH32	63.00	175.00	153.00	MH32S

Product #	Set Screws
968-000-076	MH12S
968-000-077	MH16S
968-000-078	MH20S
968-000-079	MH24S
968-000-080	MH28S
968-000-081	MH32S

PACKAGE SIZE OF 2

POSITIVE 80° DIAMOND (KAPR: 95°)

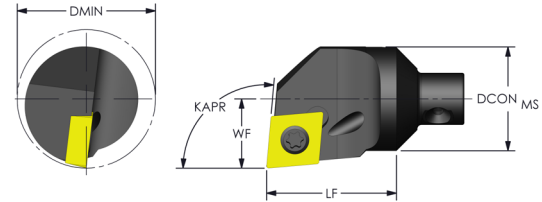

Product # LEFT HAND	Product # RIGHT HAND	Designation	DCONMS [in.]	LF [in.]	WF [in.]	DMIN [in.]	KAPR [°]	Insert	Insert Screw	Key
945-000-017	945-000-018	MH12 SCLCR/L3	0.750	0.940	0.500	0.920	95.0	CCMT 32.51	MTS-35	T-15
945-000-065	945-000-066	MH16 SCLCR/L3	1.000	1.000	0.625	1.185	95.0	CCMT 32.51	MTS-35	T-15
945-000-019	945-000-020	MH12 SCLPR/L3	0.750	0.940	0.500	0.920	95.0	CPMT 32.51	MTS-35	T-15
945-000-067	945-000-068	MH16 SCLPR/L3	1.000	1.000	0.625	1.185	95.0	CPMT 32.51	MTS-35	T-15
N/A	945-000-120	MH20 SCLCR4	1.250	1.300	0.765	1.465	95.0	CCMT 432	MTS-4	T-20
N/A	945-000-156	MH24 SCLCR4	1.500	1.520	0.890	1.730	95.0	CCMT 432	MTS-4	T-20
N/A	945-000-190	MH28 SCLCR4	1.750	1.770	1.015	2.000	95.0	CCMT 432	MTS-4	T-20
N/A	912-000-157	MH32 SCLCR4	2.000	2.030	1.281	2.400	95.0	CCMT 432	MTS-4	T-20

POSITIVE SQUARE (KAPR: 75°)

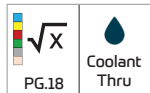
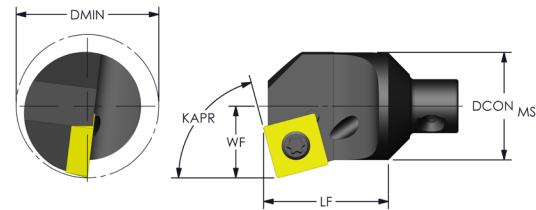

Product #	Designation	DCONMS [in.]	LF [in.]	WF [in.]	DMIN [in.]	KAPR [°]	Insert	Insert Screw	Key
945-000-028	MH12 SSKCR3	0.750	0.875	0.500	0.920	75.0	SCMT 32.51	MTS-35	T-15
945-000-078	MH16 SSKCR4	1.000	0.935	0.625	1.185	75.0	SCMT 432	MTS-4	T-20

Product #	Insert Screws
968-000-086	MTS-183
968-000-087	MTS-184
968-000-088	MTS-2
968-000-091	MTS-224
968-000-092	MTS-255
968-000-094	MTS-35
968-000-090	MTS-2.5L
968-000-052	ETS 4-40

PACKAGE SIZE OF 5

Product #	Key
968-000-156	T-6
968-000-158	T-7
968-000-149	T-10
968-000-151	T-15
968-000-153	T-20

PACKAGE SIZE OF 5

POSITIVE TRIGON (KAPR: 95°)

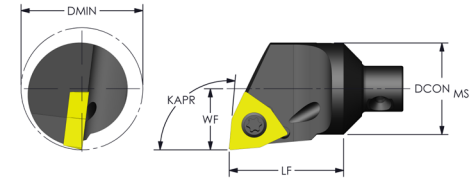

Product # LEFT HAND	Product # RIGHT HAND	Designation	DCONMS [in.]	LF [in.]	WF [in.]	DMIN [in.]	KAPR [°]	Insert	Insert Screw	Key
945-000-037	945-000-038	MH12 SWLCR/L3	0.750	0.940	0.500	0.920	95.0	WCMT 32.51	MTS-35	T-15
945-000-087	945-000-088	MH16 SWLCR/L3	1.000	1.000	0.625	1.185	95.0	WCMT 32.51	MTS-35	T-15

POSITIVE TRIANGLE (KAPR: 93°)

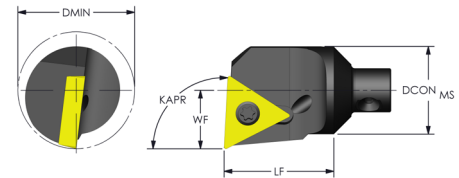
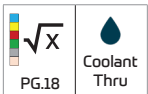

Product # LEFT HAND	Product # RIGHT HAND	Designation	DCONMS [in.]	LF [in.]	WF [in.]	DMIN [in.]	KAPR [°]	Insert	Insert Screw	Key
945-000-031	945-000-032	MH12 STUCR/L3	0.750	0.940	0.500	0.920	95.0	TCMT 32.51	MTS-35	T-15
945-000-081	945-000-082	MH16 STUCR/L3	1.000	1.000	0.625	1.185	95.0	TCMT 32.51	MTS-35	T-15

POSITIVE TRIANGLE (KAPR: 90°)

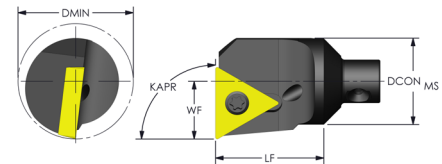
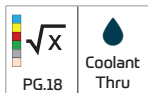

Product # LEFT HAND	Product # RIGHT HAND	Designation	DCONMS [in.]	LF [in.]	WF [in.]	DMIN [in.]	KAPR [°]	Insert	Insert Screw	Key
945-000-029	945-000-030	MH12 STFCR/L3	0.750	0.940	0.500	0.920	90.0	TCMT 32.51	MTS-35	T-15
945-000-079	945-000-080	MH16 STFCR/L3	1.000	1.000	.625	1.185	90.0	TCMT 32.51	MTS-35	T-15

Product #	Insert Screws
968-000-086	MTS-183
968-000-087	MTS-184
968-000-088	MTS-2
968-000-091	MTS-224
968-000-092	MTS-255
968-000-094	MTS-35
968-000-090	MTS-2.5L
968-000-052	ETS 4-40

PACKAGE SIZE OF 5

Product #	Key
968-000-156	T-6
968-000-158	T-7
968-000-149	T-10
968-000-151	T-15
968-000-153	T-20

PACKAGE SIZE OF 5

POSITIVE 55° DIAMOND (KAPR: 95°) PROFILING

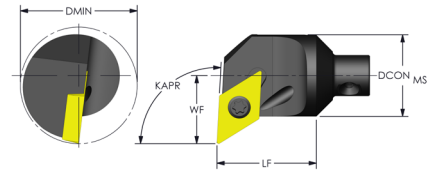
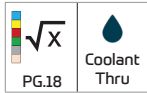

Product # LEFT HAND	Product # RIGHT HAND	Designation	DCONMS [in.]	LF [in.]	WF [in.]	DMIN [in.]	KAPR [°]	Insert	Insert Screw	Key
945-000-024	945-000-025	MH12 SDUCR/L3	0.750	0.940	0.625	1.050	95.0	DCMT 32.51	MTS-35	T-15
945-000-072	945-000-073	MH16 SDUCR/L3	1.000	1.000	0.750	1.310	95.0	DCMT 32.51	MTS-35	T-15
N/A	945-000-123	MH20 SDUCR3-8	1.250	1.300	0.800	1.500	95.0	DCMT 32.51	MTS-35	T-15
945-000-121	945-000-122	MH20 SDUCR/L3	1.250	1.300	1.000	1.700	95.0	DCMT 32.51	MTS-35	T-15
945-000-157	945-000-158	MH24 SDUCR/L3	1.500	1.520	1.120	1.960	95.0	DCMT 32.51	MTS-35	T-15
945-000-191	945-000-192	MH28 SDUCR/L3	1.750	1.770	1.250	2.230	95.0	DCMT 32.51	MTS-35	T-15
945-000-226	945-000-227	MH32 SDUCR/L3	2.000	2.030	1.375	2.500	95.0	DCMT 32.51	MTS-35	T-15

POSITIVE 55° DIAMOND (KAPR: 62.5°) PROFILING

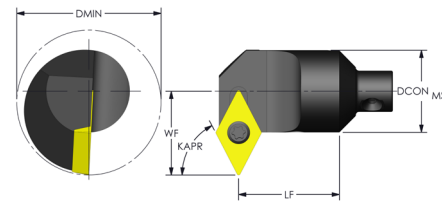
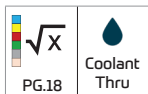

Product #	Designation	DCONMS [in.]	LF [in.]	WF [in.]	DMIN [in.]	KAPR [°]	Insert	Insert Screw	Key
945-000-021	MH12 SDNCR3	0.750	0.940	0.765	1.190	62.5	DCMT 32.51	MTS-35	T-15
945-000-069	MH16 SDNCR3	1.000	1.000	0.890	1.450	62.5	DCMT 32.51	MTS-35	T-15

POSITIVE 55° DIAMOND (KAPR: 107.5°) PROFILING

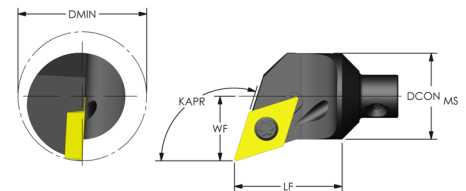
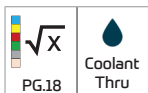

Product # LEFT HAND	Product # RIGHT HAND	Designation	DCONMS [in.]	LF [in.]	WF [in.]	DMIN [in.]	KAPR [°]	Insert	Insert Screw	Key
945-000-022	945-000-023	MH12 SDQCR/L3	0.750	0.940	0.562	1.000	107.5	DCMT 32.51	MTS-35	T-15
945-000-070	945-000-071	MH16 SDQCR/L3	1.000	1.000	0.625	1.185	107.5	DCMT 32.51	MTS-35	T-15

Product #	Insert Screws
968-000-086	MTS-183
968-000-087	MTS-184
968-000-088	MTS-2
968-000-091	MTS-224
968-000-092	MTS-255
968-000-094	MTS-35
968-000-090	MTS-2.5L
968-000-052	ETS 4-40

Product #	Key
968-000-156	T-6
968-000-158	T-7
968-000-149	T-10
968-000-151	T-15
968-000-153	T-20

PACKAGE SIZE OF 5

PACKAGE SIZE OF 5

POSITIVE 35° DIAMOND (KAPR: 93°) PROFILING

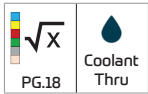
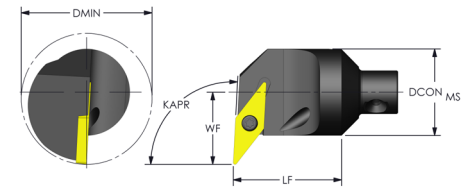

Product # LEFT HAND	Product # RIGHT HAND	Designation	DCONMS [in.]	LF [in.]	WF [in.]	DMIN [in.]	KAPR [°]	Insert	Insert Screw	Key
945-000-035	945-000-036	MH12 SVUBR/L2	0.750	0.940	0.625	1.045	93.0	VBMT 21.51	MTS-2.5L	T-7
945-000-085	945-000-086	MH16 SVUBR/L3	1.000	1.000	0.875	1.435	93.0	VBMT 331	MTS-3.5L	T-15

POSITIVE 35° DIAMOND (KAPR: 142°) PROFILING

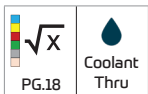
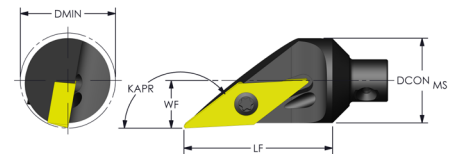

Product # LEFT HAND	Product # RIGHT HAND	Designation	DCONMS [in.]	LF [in.]	WF [in.]	DMIN [in.]	KAPR [°]	Insert	Insert Screw	Key
945-000-033	945-000-034	MH12 SVJBR/L3	0.750	1.315	0.421	0.840	142.0	VBMT 331	MTS-3.5L	T-15
945-000-083	945-000-084	MH16 SVJBR/L3	1.000	1.375	0.546	1.110	142.0	VBMT 331	MTS-3.5L	T-15
945-000-124	945-000-125	MH20 SVJBR/L3	1.250	1.675	0.671	1.700	142.0	VBMT 331	MTS-3.5L	T-15
945-000-161	945-000-162	MH24 SVJBR/L3	1.500	1.895	0.796	1.960	142.0	VBMT 331	MTS-3.5L	T-15
945-000-193	945-000-194	MH28 SVJBR/L3	1.750	2.145	0.921	2.230	142.0	VBMT 331	MTS-3.5L	T-15
945-000-228	945-000-229	MH32 SVJBR/L3	2.000	2.405	1.046	2.500	142.0	VBMT 331	MTS-3.5L	T-15

POSITIVE 55° DIAMOND(KAPR: 95°) BACK FACING

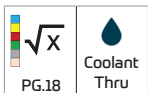
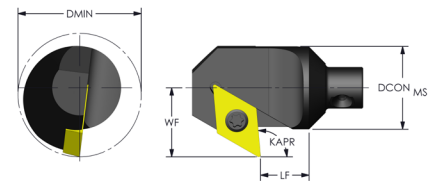

Product # LEFT HAND	Product # RIGHT HAND	Designation	DCONMS [in.]	LF [in.]	WF [in.]	DMIN [in.]	KAPR [°]	Insert	Insert Screw	Key
945-000-026	945-000-027	MH12 SDXCR/L3	0.750	0.440	0.625	1.050	95.0	DCMT 32.51	MTS-35	T-15
945-000-074	945-000-075	MH16 SDXCR/L3	1.000	0.525	0.750	1.310	95.0	DCMT 32.51	MTS-35	T-15

Product #	Insert Screws
968-000-086	MTS-183
968-000-087	MTS-184
968-000-088	MTS-2
968-000-091	MTS-224
968-000-092	MTS-255
968-000-094	MTS-35
968-000-090	MTS-2.5L
968-000-052	ETS 4-40

PACKAGE SIZE OF 5

Product #	Key
968-000-156	T-6
968-000-158	T-7
968-000-149	T-10
968-000-151	T-15
968-000-153	T-20

PACKAGE SIZE OF 5

Product #	Insert Screws
968-000-093	MTS-3.5L
968-000-095	MTS-4
968-000-096	MTS-526

PACKAGE SIZE OF 1

POSITIVE ROUND

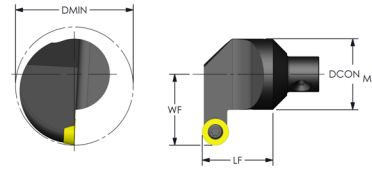
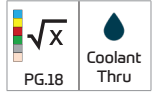

Product # LEFT HAND	Product # RIGHT HAND	Designation	DCONMS [in.]	LF [in.]	WF [in.]	DMIN [in.]	Insert	Screw
945-000-076	945-000-077	MH16 SRNCR/L3	1.000	1.000	1.000	1.560	RCMT 32.5	MTS-35
945-000-159	945-000-160	MH24 SRNCR/L4	1.500	1.520	1.250	2.090	RCMT 43	MTS-4

NEGATIVE 80° DIAMOND (KAPR: 95°)

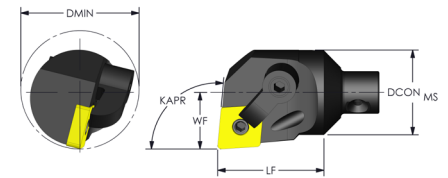
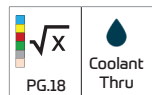

Product # LEFT HAND	Product # RIGHT HAND	Designation	DCONMS [in.]	LF [in.]	WF [in.]	DMIN [in.]	KAPR [°]	Insert	Shim	Clamp	Clamp Screw	Lock Pin
945-000-005	945-000-006	MH12 MCLNR/L3	0.750	0.940	0.500	0.920	95.0	CNMG 322	N/A	CL-7	XNS-36	NL-33
945-000-044	945-000-046	MH16 MCLNR/L3	1.000	1.000	0.640	1.200	95.0	CNMG 322	N/A	CL-7	XNS-36	NL-33
945-000-045	945-000-047	MH16 MCLNR/L4	1.000	1.000	0.640	1.200	95.0	CNMG 432	N/A	CL-20	XNS-47	NL-44
945-000-096	945-000-097	MH20 MCLNR/L4	1.250	1.300	0.765	1.470	95.0	CNMG 432	ICSN-433	CL-20	XNS-47	NL-46
945-000-133	945-000-134	MH24 MCLNR/L4	1.500	1.520	.890	1.730	95.0	CNMG 432	ICSN-433	CL-20	XNS-47	NL-46
945-000-170	945-000-171	MH28 MCLNR/L4	1.750	1.770	1.015	1.995	95.0	CNMG 432	ICSN-433	CL-20	XNS-47	NL-46
945-000-200	945-000-202	MH32 MCLNR/L4	2.000	2.030	1.281	2.400	95.0	CNMG 432	ICSN-433	CL-20	XNS-47	NL-46
945-000-203	945-000-205	MH32 MCLNR/L5	2.000	2.030	1.281	2.400	95.0	CNMG 543	ICSN-533	CL-12	XNS-510	NL-58

NEGATIVE 80° DIAMOND (KAPR: 75°)

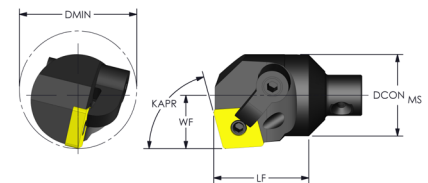
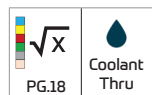

Product # LEFT HAND	Product # RIGHT HAND	Designation	DCONMS [in.]	LF [in.]	WF [in.]	DMIN [in.]	KAPR [°]	Insert	Shim	Clamp	Clamp Screw	Lock Pin
945-000-003	945-000-004	MH12 MCKNR/L3	0.750	0.875	0.490	0.910	80.0	CNMG 322	N/A	CL-7	XNS-36	NL-33
945-000-042	945-000-043	MH16 MCKNR/L3	1.000	0.935	0.630	1.190	80.0	CNMG 322	N/A	CL-7	XNS-36	NL-33
945-000-094	945-000-096	MH20 MCKNR/L4	1.250	1.210	0.755	1.455	80.0	CNMG 432	ICSN-433	CL-20	XNS-47	NL-46
945-000-131	945-000-132	MH24 MCKNR/L4	1.500	1.430	0.880	1.720	80.0	CNMG 432	ICSN-433	CL-20	XNS-47	NL-46
945-000-168	945-000-169	MH28 MCKNR/L4	1.750	1.680	1.005	1.985	80.0	CNMG 432	ICSN-433	CL-20	XNS-47	NL-46
945-000-200	945-000-201	MH32 MCKNR/L4	2.000	1.940	1.271	2.390	80.0	CNMG 432	ICSN-433	CL-20	XNS-47	NL-46

Product #	Clamp Screw
968-000-176	XNS-36
968-000-177	XNS-47
968-000-178	XNS-48
968-000-179	XNS-510
968-000-180	XNS-58
968-000-181	XNS-59

PACKAGE SIZE OF 5

Product #	Lock Pin
968-000-097	NL-33
968-000-098	NL-33L
968-000-099	NL-34
968-000-100	NL-34L
968-000-101	NL-44
968-000-102	NL-46
968-000-103	NL-56
968-000-104	NL-58
968-000-105	NL-68
968-000-106	NL-68L

PACKAGE SIZE OF 5

NEGATIVE SQUARE (KAPR: 75°)

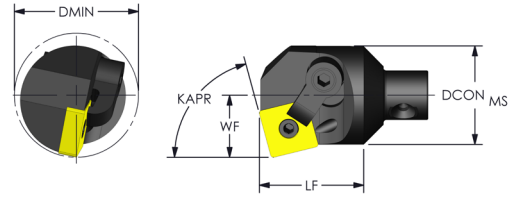
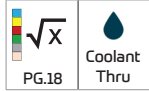

Product #	Designation	DCONMS [in.]	LF [in.]	WF [in.]	DMIN [in.]	KAPR [°]	Insert	Shim	Clamp	Clamp Screw	Lock Pin
945-000-050	MH16 MSKNR4	1.000	1.060	0.630	1.190	75.0	SNMG 432	N/A	CL-20	XNS-47	NL-44
945-000-105	MH20 MSKNR4	1.250	1.210	0.755	1.455	75.0	SNMG 432	ISSN-432	CL-20	XNS-47	NL-46
945-000-141	MH24 MSKNR4	1.500	1.430	0.880	1.720	75.0	SNMG 432	ISSN-432	CL-20	XNS-47	NL-46
945-000-212	MH32 MSKNR4	2.000	1.680	1.271	2.390	75.0	SNMG 432	ISSN-432	CL-20	XNS-47	NL-46

NEGATIVE TRIGON (KAPR: 95°)

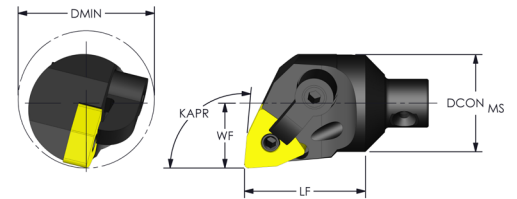
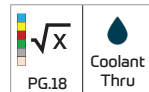

Product # LEFT HAND	Product # RIGHT HAND	Designation	DCONMS [in.]	LF [in.]	WF [in.]	DMIN [in.]	KAPR [°]	Insert	Shim	Clamp	Clamp Screw	Lock Pin
945-000-013	945-000-014	MH12 MWLNR/L3	0.750	0.940	0.500	0.920	95.0	WNMG 332	N/A	CL-7	XNS-36	NL-33L
945-000-057	945-000-058	MH16 MWLNR/L3	1.000	1.000	0.640	1.200	95.0	WNMG 332	N/A	CL-7	XNS-36	NL-33L
945-000-058	945-000-060	MH16 MWLNR/L4	1.000	1.000	0.640	1.240	95.0	WNMG 432	N/A	CL-20	XNS-47	NL-44
945-000-116	945-000-117	MH20 MWLNR/L4	1.250	1.300	0.765	1.470	95.0	WNMG 432	IWSN-433	CL-20	XNS-47	NL-46
945-000-152	945-000-153	MH24 MWLNR/L4	1.500	1.520	.890	1.730	95.0	WNMG 432	IWSN-433	CL-20	XNS-47	NL-46
945-000-186	945-000-187	MH28 MWLNR/L4	1.750	1.770	1.015	1.995	95.0	WNMG 432	IWSN-433	CL-20	XNS-47	NL-46
945-000-221	945-000-222	MH32 MWLNR/L4	2.000	2.030	1.281	2.400	95.0	WNMG 432	IWSN-433	CL-20	XNS-47	NL-46

NEGATIVE TRIANGLE (KAPR: 93°)

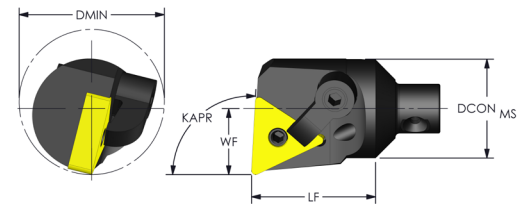
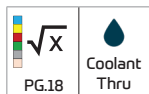

Product # LEFT HAND	Product # RIGHT HAND	Designation	DCONMS [in.]	LF [in.]	WF [in.]	DMIN [in.]	KAPR [°]	Insert	Shim	Clamp	Clamp Screw	Lock Pin
945-000-011	945-000-012	MH12 MTUNR/L3	0.750	0.940	0.500	0.920	93.0	TNMG 332	N/A	CL-7	XNS-36	NL-33L
945-000-053	945-000-054	MH16 MTUNR/L3	1.000	1.000	0.640	1.200	93.0	TNMG 332	N/A	CL-7	XNS-36	NL-33L
945-000-110	945-000-112	MH20 MTUNR/L3	1.250	1.300	0.765	1.470	93.0	TNMG 332	ITSN-323	CL-7	XNS-36	NL-34L
945-000-146	945-000-148	MH24 MTUNR/L3	1.500	1.520	0.890	1.470	93.0	TNMG 332	ITSN-323	CL-7	XNS-36	NL-34L
945-000-111	945-000-113	MH20 MTUNR/L4	1.250	1.300	0.765	1.730	93.0	TNMG 432	ITSN-433	CL-20	XNS-47	NL-46
945-000-147	945-000-149	MH24 MTUNR/L4	1.500	1.520	0.890	1.730	93.0	TNMG 432	ITSN-433	CL-20	XNS-47	NL-46
945-000-180	945-000-181	MH28 MTUNR/L4	1.750	1.770	1.015	1.995	93.0	TNMG 432	ITSN-433	CL-20	XNS-47	NL-46
945-000-215	945-000-216	MH32 MTUNR/L4	2.000	2.030	1.281	2.400	93.0	TNMG 432	ITSN-433	CL-20	XNS-47	NL-46

NEGATIVE TRIANGLE (KAPR: 90°)

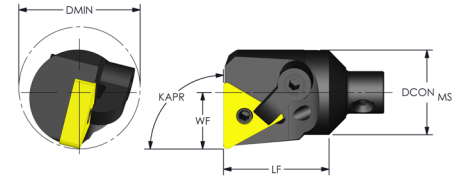

Product # LEFT HAND	Product # RIGHT HAND	Designation	DCONMS [in.]	LF [in.]	WF [in.]	DMIN [in.]	KAPR [°]	Insert	Shim	Clamp	Clamp Screw	Lock Pin
945-000-009	945-000-010	MH12 MTFNR/L3	0.750	0.940	0.500	0.920	90.0	TNMG 332	N/A	CL-7	XNS-36	NL-33L
945-000-051	945-000-052	MH16 MTFNR/L3	1.000	1.000	0.640	1.200	90.0	TNMG 332	N/A	CL-7	XNS-36	NL-33L
945-000-106	945-000-108	MH20 MTFNR/L3	1.250	1.300	0.765	1.470	90.0	TNMG 332	ITSN-323	CL-7	XNS-36	NL-34L
945-000-142	945-000-144	MH24 MTFNR/L3	1.500	1.520	0.890	1.730	90.0	TNMG 332	ITSN-323	CL-7	XNS-36	NL-34L
945-000-107	945-000-109	MH20 MTFNR/L4	1.250	1.300	0.765	1.470	90.0	TNMG 432	ITSN-433	CL-20	XNS-47	NL-46
945-000-143	945-000-145	MH24 MTFNR/L4	1.500	1.520	0.890	1.730	90.0	TNMG 432	ITSN-433	CL-20	XNS-47	NL-46
945-000-178	945-000-179	MH28 MTFNR/L4	1.750	1.770	1.015	1.995	90.0	TNMG 432	ITSN-433	CL-20	XNS-47	NL-46
945-000-213	945-000-214	MH32 MTFNR/L4	2.000	2.030	1.281	2.400	90.0	TNMG 432	ITSN-433	CL-20	XNS-47	NL-46

NEGATIVE 55° DIAMOND (KAPR: 93°) PROFILING

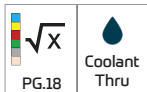
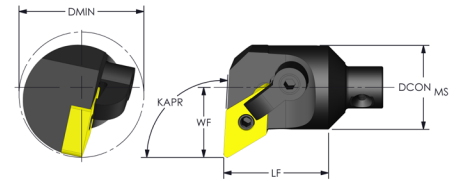

Product # LEFT HAND	Product # RIGHT HAND	Designation	DCONMS [in.]	LF [in.]	WF [in.]	DMIN [in.]	KAPR [°]	Insert	Shim	Clamp	Clamp Screw	Lock Pin
945-000-007	945-000-008	MH12 MDUNR/L3	0.750	0.940	0.625	1.050	93.0	DNMG 332	N/A	CL-7	XNS-36	NL-33L
945-000-048	945-000-049	MH16 MDUNR/L3	1.000	1.000	0.750	1.310	93.0	DNMG 332	N/A	CL-7	XNS-36	NL-33L
N/A	945-000-102	MH20 MDUNR4-7	1.250	1.300	0.775	1.475	93.0	DNMG 432	IDSN-433	CL-22	XNS-48	NL-46
945-000-100	945-000-101	MH20 MDUNR/L4	1.250	1.300	1.000	1.700	93.0	DNMG 432	IDSN-433	CL-22	XNS-48	NL-46
945-000-137	945-000-138	MH24 MDUNR/L4	1.500	1.520	1.120	1.960	93.0	DNMG 432	IDSN-433	CL-22	XNS-48	NL-46
945-000-174	945-000-175	MH28 MDUNR/L4	1.750	1.770	1.250	2.250	93.0	DNMG 432	IDSN-433	CL-22	XNS-48	NL-46
945-000-208	945-000-209	MH32 MDUNR/L4	2.000	2.030	1.375	2.500	93.0	DNMG 432	IDSN-433	CL-22	XNS-48	NL-46

NEGATIVE 55° DIAMOND (KAPR: 107.5°) PROFILING

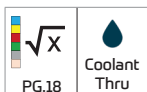
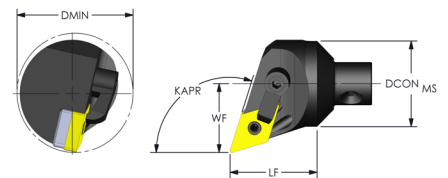

Product # LEFT HAND	Product # RIGHT HAND	Designation	DCONMS [in.]	LF [in.]	WF [in.]	DMIN [in.]	KAPR [°]	Insert	Shim	Clamp	Clamp Screw	Lock Pin
945-000-098	945-000-099	MH20 MDQNR/L4	1.250	1.300	1.000	1.700	107.5	DNMG 432	IDSN-433	CL-22	XNS-48	NL-46
945-000-135	945-000-136	MH24 MDQNR/L4	1.500	1.520	1.120	1.960	107.5	DNMG 432	IDSN-433	CL-22	XNS-48	NL-46
945-000-172	945-000-173	MH28 MDQNR/L4	1.750	1.770	1.250	2.250	107.5	DNMG 432	IDSN-433	CL-22	XNS-48	NL-46
945-000-206	945-000-207	MH32 MDQNR/L4	2.000	2.030	1.281	2.400	107.5	DNMG 432	IDSN-433	CL-22	XNS-48	NL-46

NEGATIVE 35° DIAMOND (KAPR: 93°) PROFILING

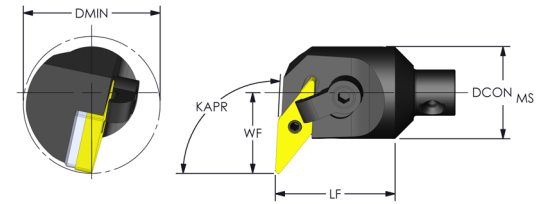
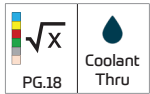

Product # LEFT HAND	Product # RIGHT HAND	Designation	DCONMS [in.]	LF [in.]	WF [in.]	DMIN [in.]	KAPR [°]	Insert	Shim	Clamp	Clamp Screw	Lock Pin
945-000-055	945-000-056	MH16 MVUNR/L3	1.000	1.300	0.875	1.435	93.0	VNMG 332	IVSN-322	CL-20	XNS-47	NL-34L
945-000-114	945-000-115	MH20 MVUNR/L3	1.250	1.300	1.000	1.700	93.0	VNMG 332	IVSN-322	CL-20	XNS-47	NL-34L
945-000-150	945-000-151	MH24 MVUNR/L3	1.500	1.520	1.120	2.000	93.0	VNMG 332	IVSN-322	CL-20	XNS-47	NL-34L
945-000-182	945-000-181	MH28 MVUNR/L3	1.750	1.770	1.250	2.250	93.0	VNMG 332	IVSN-322	CL-20	XNS-47	NL-34L
945-000-217	945-000-216	MH32 MVUNR/L3	2.000	2.030	1.375	2.500	93.0	VNMG 332	IVSN-322	CL-20	XNS-47	NL-34L
945-000-183	945-000-185	MH28 MVUNR/L4	1.750	1.770	1.250	2.250	93.0	VNMG 432	IVSN-432	CL-22	XNS-48	NL-46
945-000-218	945-000-220	MH32 MVUNR/L4	2.000	2.030	1.375	2.500	93.0	VNMG 432	IVSN-432	CL-22	XNS-48	NL-46

NEGATIVE 55° DIAMOND (KAPR: 95°) BACK FACING

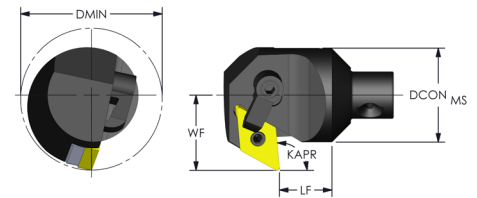
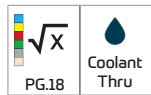

Product # LEFT HAND	Product # RIGHT HAND	Designation	DCONMS [in.]	LF [in.]	WF [in.]	DMIN [in.]	KAPR [°]	Insert	Shim	Clamp	Clamp Screw	Lock Pin
945-000-103	945-000-104	MH20 MDXNR/L4	1.250	0.700	1.000	1.700	95.0	DNMG 432	IDSN-433	CL-22	XNS-48	NL-46
945-000-139	945-000-140	MH24 MDXNR/L4	1.500	0.650	1.120	1.960	95.0	DNMG 432	IDSN-433	CL-22	XNS-48	NL-46
945-000-176	945-000-177	MH28 MDXNR/L4	1.750	0.780	1.250	2.250	95.0	DNMG 432	IDSN-433	CL-22	XNS-48	NL-46
945-000-210	945-000-211	MH32 MDXNR/L4	2.000	0.780	1.500	2.620	95.0	DNMG 432	IDSN-433	CL-22	XNS-48	NL-46

Product #	Clamp
968-000-016	CL-6
968-000-017	CL-7
968-000-020	CL-9
968-000-010	CL-12
968-000-011	CL-19
968-000-012	CL-20

PACKAGE SIZE OF 1

Product #	Clamp
968-000-013	CL-21
968-000-014	CL-22
968-000-015	CL-30
968-000-018	CL-84
968-000-019	CL-85

PACKAGE SIZE OF 1

Product #	Clamp Screw
968-000-176	XNS-36
968-000-177	XNS-47
968-000-178	XNS-48
968-000-179	XNS-510
968-000-180	XNS-58
968-000-181	XNS-59

PACKAGE SIZE OF 5

Product #	Lock Pin
968-000-097	NL-33
968-000-098	NL-33L
968-000-099	NL-34
968-000-100	NL-34L
968-000-101	NL-44
968-000-102	NL-46
968-000-103	NL-56
968-000-104	NL-58
968-000-105	NL-68
968-000-106	NL-68L

PACKAGE SIZE OF 5

PULLBACK CLAMP NEGATIVE 80° DIAMOND (KAPR: 95°)

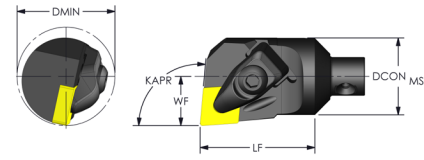

Product #	Designation	DCONMS [in.]	LF [in.]	WF [in.]	DMIN [in.]	KAPR [°]	Insert	Shim	Shim Screw	Clamp Assy.
945-000-039	MH16 DCLNR4	1.000	1.500	0.640	1.200	95.0	CNMG 432	N/A	N/A	PB4-CA
945-000-089	MH20 DCLNR4	1.250	1.500	0.765	1.470	95.0	CNMG 432	ICSN-433	PB4-SS	PB4-CA
945-000-126	MH24 DCLNR4	1.500	1.520	.890	1.730	95.0	CNMG 432	ICSN-433	PB4-SS	PB4-CA
945-000-163	MH28 DCLNR4	1.750	1.770	1.015	1.995	95.0	CNMG 432	ICSN-433	PB4-SS	PB4-CA
945-000-195	MH32 DCLNR4	2.000	2.030	1.281	2.400	95.0	CNMG 432	ICSN-433	PB4-SS	PB4-CA

PULLBACK CLAMP NEGATIVE 55° DIAMOND (KAPR: 93°)

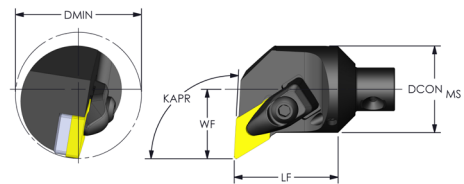
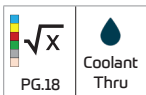

Product #	Designation	DCONMS [in.]	LF [in.]	WF [in.]	DMIN [in.]	KAPR [°]	Insert	Shim	Shim Screw	Clamp Assy.
945-000-090	MH20 DDUNR4	1.250	1.500	1.000	1.700	93.0	DNMG 432	IDSN-433	PB4-SS	PB4-CA
945-000-127	MH24 DDUNR4	1.500	1.520	1.120	1.960	93.0	DNMG 432	IDSN-433	PB4-SS	PB4-CA
945-000-164	MH28 DDUNR4	1.750	1.770	1.250	2.250	93.0	DNMG 432	IDSN-433	PB4-SS	PB4-CA
945-000-196	MH32 DDUNR4	2.000	2.030	1.375	2.500	93.0	DNMG 432	IDSN-433	PB4-SS	PB4-CA

PULLBACK CLAMP NEGATIVE TRIANGLE (KAPR: 93°)

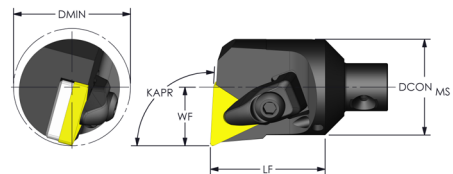
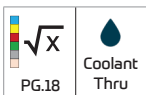

Product #	Designation	DCONMS [in.]	LF [in.]	WF [in.]	DMIN [in.]	KAPR [°]	Insert	Shim	Shim Screw	Clamp Assy.
945-000-091	MH20 DTUNR4	1.250	1.500	0.765	1.470	93.0	TNMG 432	ITSN-433	PB4-SS	PB4-CA
945-000-128	MH24 DTUNR4	1.500	1.520	.890	1.730	93.0	TNMG 432	ITSN-433	PB4-SS	PB4-CA
945-000-165	MH28 DTUNR4	1.750	1.770	1.015	1.995	93.0	TNMG 432	ITSN-433	PB4-SS	PB4-CA
945-000-197	MH32 DTUNR4	2.000	2.030	1.281	2.400	93.0	TNMG 432	ITSN-433	PB4-SS	PB4-CA

Product #	Shim Screw
968-000-109	PB3-SS
968-000-111	PB4-SS

PACKAGE SIZE OF 5

Product #	Clamp Assy.
968-000-107	PB3-CA
968-000-110	PB4-CA

PACKAGE SIZE OF 1

THREADING / GROOVING LAYDOWN

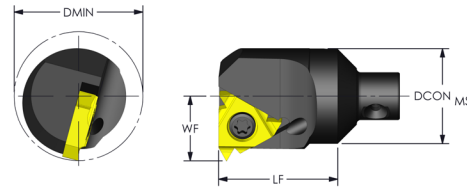
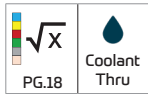

Product #	Designation RIGHT HAND	DCONMS [in.]	LF [in.]	WF [in.]	DMIN [in.]	Insert	Insert Screw	Anvil Screw	Anvil
945-000-002	MH12 LSER3	0.750	0.940	0.510	0.930	3IR	MTS-35	N/A	N/A
945-000-041	MH16 LSER3	1.000	1.000	0.650	1.210	3IR	SA3T	SY3T	YI3
945-000-093	MH20 LSER3	1.250	1.300	0.770	1.470	3IR	SA3T	SY3T	YI3
945-000-130	MH24 LSER3	1.500	1.520	0.900	1.740	3IR	SA3T	SY3T	YI3
945-000-167	MH28 LSER3	1.750	1.770	1.090	2.070	3IR	SA3T	SY3T	YI3
945-000-199	MH32 LSER3	2.000	2.030	1.281	2.400	3IR	SA3T	SY3T	YI3

Product #	Designation LEFT HAND	DCONMS [in.]	LF [in.]	WF [in.]	DMIN [in.]	Insert	Insert Screw	Anvil Screw	Anvil
945-000-001	MH12 LSEL3	0.750	0.940	0.510	0.930	3IL	MTS-35	N/A	N/A
945-000-040	MH16 LSEL3	1.000	1.000	0.650	1.210	3IL	SA3T	SY3T	YE3
945-000-092	MH20 LSEL3	1.250	1.300	0.770	1.470	3IL	SA3T	SY3T	YE3
945-000-129	MH24 LSEL3	1.500	1.520	0.900	1.740	3IL	SA3T	SY3T	YE3
945-000-166	MH28 LSEL3	1.750	1.770	1.090	2.070	3IL	SA3T	SY3T	YE3
945-000-198	MH32 LSEL3	2.000	2.030	1.281	2.400	3IL	SA3T	SY3T	YE3

Product #	Clamp
968-000-016	CL-6
968-000-017	CL-7
968-000-020	CL-9
968-000-010	CL-12
968-000-011	CL-19
968-000-012	CL-20

PACKAGE SIZE OF 1

Product #	Clamp
968-000-013	CL-21
968-000-014	CL-22
968-000-015	CL-30
968-000-018	CL-84
968-000-019	CL-85

PACKAGE SIZE OF 1

Product #	Anvil
968-000-185	YI3
968-000-182	YE3
968-000-187	YI4
968-000-186	YI3M-1.5N
968-000-183	YE4
968-000-188	YI5
968-000-184	YE5

PACKAGE SIZE OF 1

Product #	Anvil Screw
968-000-146	SY3T
968-000-147	SY4T
968-000-148	SY5T

PACKAGE SIZE OF 5

Product #	Insert Screw
968-000-124	SA3T
968-000-125	SA4T
968-000-126	SA5T

PACKAGE SIZE OF 5

THREADING / GROOVING, NOTCH STYLE

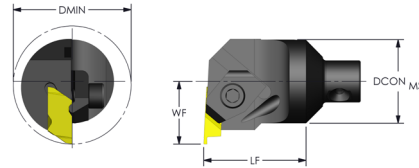

Product # RIGHT HAND	Designation	DCONMS [in.]	LF [in.]	WF [in.]	DMIN [in.]	Insert	Clamp	Clamp Screw
945-000-016	MH12 NER2	0.750	0.920	0.562	1.120	NG 2L	CM-75	6-32
945-000-063	MH16 NER2	1.000	1.180	0.688	1.380	NG 2L	CM-75	6-32
945-000-064	MH16 NER3	1.000	1.180	0.688	1.380	NG 3L	CM-73	10-32
945-000-119	MH20 NER3	1.250	1.300	0.875	1.750	NG 3L	CM-73	10-32
945-000-155	MH24 NER3	1.500	1.520	1.000	2.000	NG 3L	CM-73	10-32
945-000-189	MH28 NER3	1.750	1.770	1.125	2.250	NG 3L	CM-73	10-32
945-000-224	MH32 NER3	2.000	2.030	1.250	2.500	NG 3L	CM-73	10-32

Product # LEFT HAND	Designation	DCONMS [in.]	LF [in.]	WF [in.]	DMIN [in.]	Insert	Clamp	Clamp Screw
945-000-015	MH12 NEL2	0.750	0.920	0.562	1.120	NG 2R	CM-74	6-32
945-000-061	MH16 NEL2	1.000	1.180	0.688	1.380	NG 2R	CM-74	6-32
945-000-062	MH16 NEL3	1.000	1.180	0.688	1.380	NG 3R	CM-72	10-32
945-000-118	MH20 NEL3	1.250	1.300	0.875	1.750	NG 3R	CM-72	10-32
945-000-154	MH24 NEL3	1.500	1.520	1.000	2.000	NG 3R	CM-72	10-32
945-000-188	MH28 NEL3	1.750	1.770	1.125	2.250	NG 3R	CM-72	10-32
945-000-223	MH32 NEL3	2.000	2.030	1.250	2.500	NG 3R	CM-72	10-32

Product #	Clamp
968-000-025	CM-72
968-000-026	CM-73
968-000-027	CM-74
968-000-028	CM-75
968-000-021	CM-120
968-000-022	CM-121
968-000-023	CM-146
968-000-024	CM-147

PACKAGE SIZE OF 1

Product #	Clamp Screw
968-000-005	6-32
968-000-003	10-32
968-000-096	MTS-526

PACKAGE SIZE OF 5

C STYLE

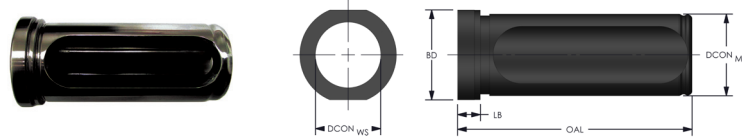

Product #	DESIGNATION	DCONMS [in.]	DCONWS [in.]	LB [in.]	OAL [in.]
901-000-001	UT-12C-037	1.250	0.375	0.270	3.500
901-000-002	UT-12C-050	1.250	0.500	0.270	3.500
901-000-003	UT-12C-062	1.250	0.625	0.270	3.500
901-000-004	UT-12C-075	1.250	0.750	0.270	3.500
901-000-005	UT-12C-100	1.250	1.000	0.270	3.500
901-000-011	UT-13C-037	1.500	0.375	0.270	3.600
901-000-012	UT-13C-050	1.500	0.500	0.270	3.600
901-000-013	UT-13C-062	1.500	0.625	0.270	3.600
901-000-014	UT-13C-075	1.500	0.750	0.270	3.600
901-000-015	UT-13C-100	1.500	1.000	0.270	3.600
901-000-016	UT-13C-125	1.500	1.250	0.270	3.600

CX STYLE

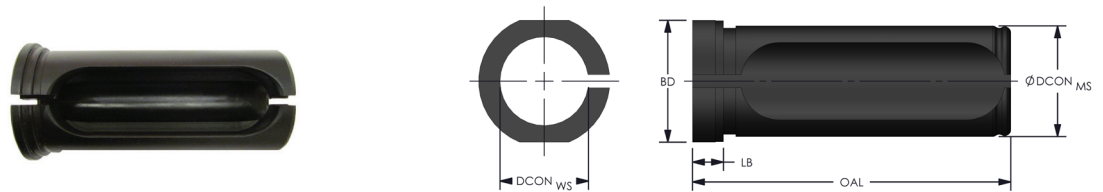

Product #	DESIGNATION	DCONMS [in.]	DCONWS [in.]	LB [in.]	OAL [in.]
901-000-006	UT-12CX-037	1.250	0.375	0.270	3.500
901-000-007	UT-12CX-050	1.250	0.500	0.270	3.500
901-000-008	UT-12CX-062	1.250	0.625	0.270	3.500
901-000-009	UT-12CX-075	1.250	0.750	0.270	3.500
901-000-010	UT-12CX-100	1.250	1.000	0.270	3.500
901-000-017	UT-13CX-037	1.500	0.375	0.270	3.600
901-000-018	UT-13CX-050	1.500	0.500	0.270	3.600
901-000-019	UT-13CX-062	1.500	0.625	0.270	3.600
901-000-020	UT-13CX-075	1.500	0.750	0.270	3.600
901-000-021	UT-13CX-100	1.500	1.000	0.270	3.600
901-000-022	UT-13CX-125	1.500	1.250	0.270	3.600

Product #	DESIGNATION	DCONMS [in.]	DCONWS [in.]	LB [in.]	OAL [in.]
901-000-023	UT-73CX-10MM	1.500	0.3937	0.270	3.600
901-000-024	UT-73CX-12MM	1.500	0.4720	0.270	3.600
901-000-025	UT-73CX-16MM	1.500	0.6290	0.270	3.600
901-000-026	UT-73CX-20MM	1.500	0.7874	0.270	3.600
901-000-027	UT-73CX-25MM	1.500	0.9840	0.270	3.600
901-000-028	UT-93CX-10MM	40.00(mm)	10.00(mm)	0.270	3.600
901-000-029	UT-93CX-12MM	40.00(mm)	12.00(mm)	0.270	3.600
901-000-030	UT-93CX-16MM	40.00(mm)	16.00(mm)	0.270	3.600
901-000-031	UT-93CX-20MM	40.00(mm)	20.00(mm)	0.270	3.600
901-000-032	UT-93CX-25MM	40.00(mm)	25.00(mm)	0.270	3.600

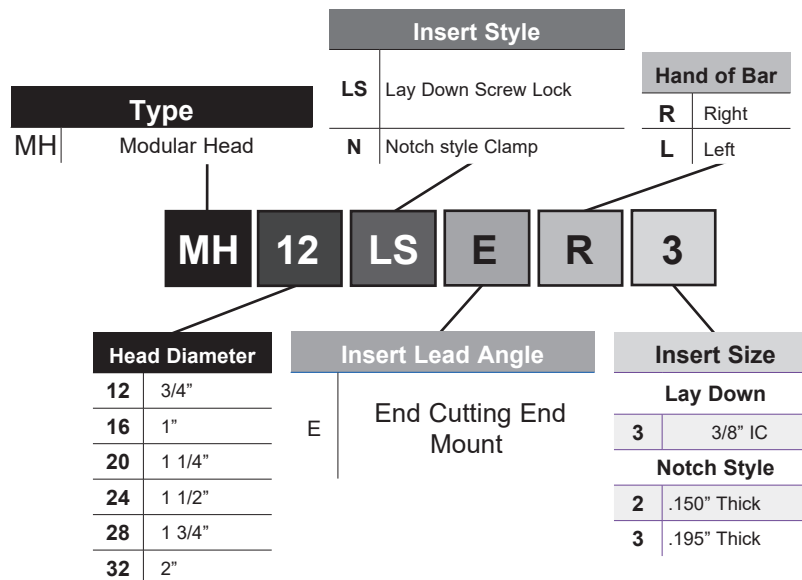
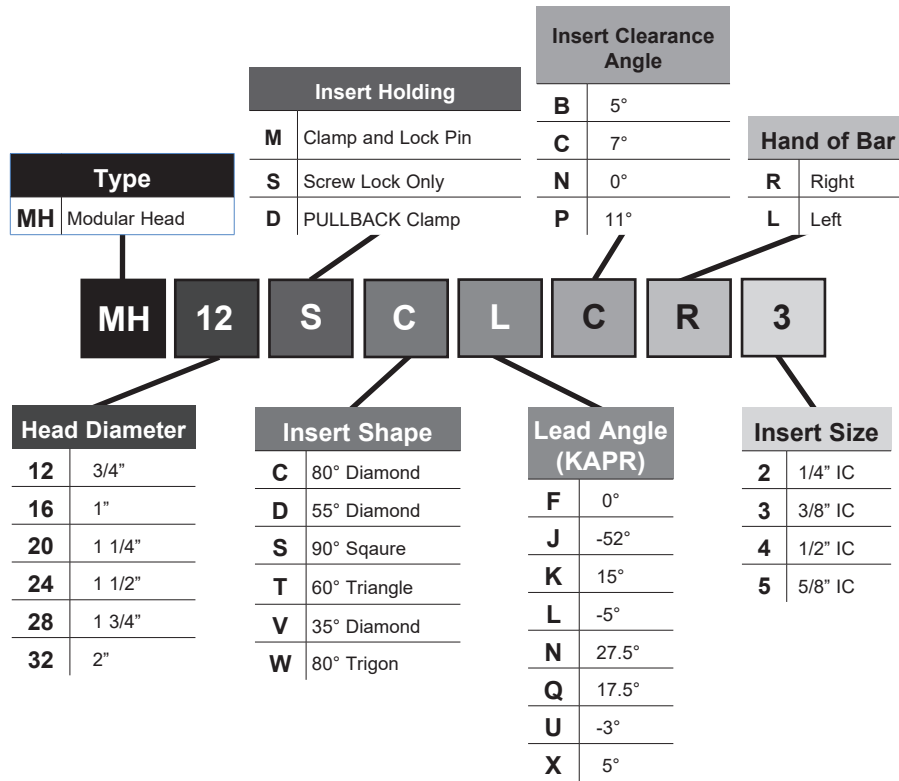



Down To The Cutting Edge

We offer an extensive selection of standard inserts designed to enhance the efficiency and precision of your turning, milling, and drilling operations. Each insert is meticulously crafted, ensuring compatibility with a variety of component designs, sizes, and materials. Whether you're working with metals, plastics, or composites, our inserts are engineered to meet high performance and durability standards.

LEARN MORE

Scan the QR code
to find the right insert for your
cutting application



YOUR COMPLETE TOOL MAKING AUTHORITY®

ARCH Cutting Tools is more than an American manufacturer of metal cutting tools. We are engineering the future.

We draw on over 100 years of collective engineering expertise and innovative materials to provide solutions for complex manufacturing processes. And we view every manufacturing challenge as an opportunity to collaborate and design cutting-edge solutions that maximize the end-user environment.

Whether it's a standard product, complex custom, reconditioned tool, or a complete tooling package, our solutions enable end-users to run longer, cut faster, and machine with greater precision.

We are Your Complete Tool Making Authority®.



V. 1.3.1